

Technical Support

☎ 01273 811011



support@paxton.co.uk

Technical help is available: Monday - Friday from 07:00 - 19:00 (GMT)
Saturday from 09:00 - 13:00 (GMT)

Documentation on all Paxton products can be found on our website - <http://www.paxton.co.uk/>

This wireless unit requires a Net2Air bridge to communicate with the server PC.

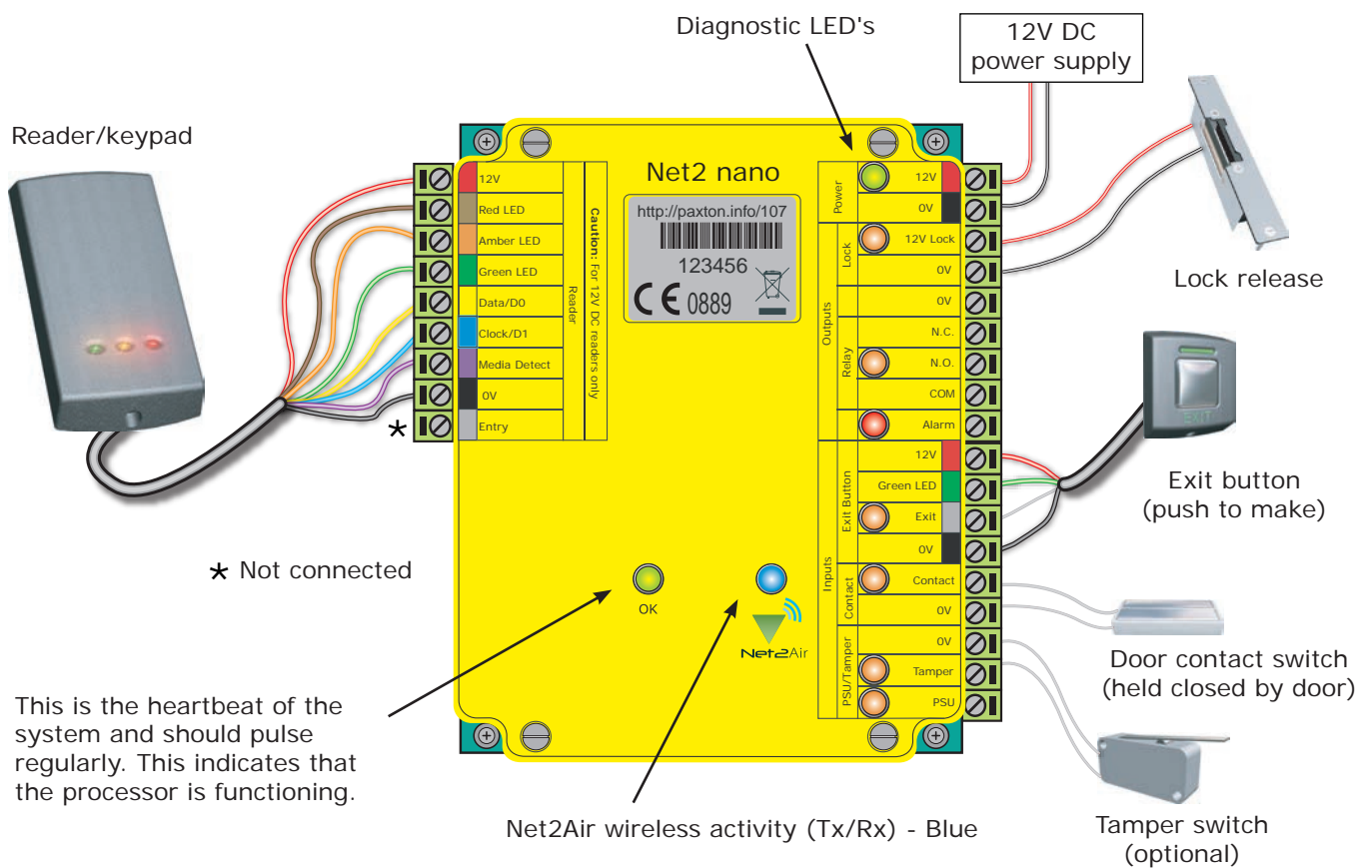

A new unit requires approximately 30 seconds after initial power up to self configure. During this time the OK LED will not be flashing.

The unit will not operate correctly until this function has completed.

LED indications

12V	(Green)	- Power LED
Lock	(Orange)	- The 12V lock output is energised
Relay	(Orange)	- The relay is energised - (N.O./COM contacts are closed)
Alarm	(Red)	- 12V Alarm output is active
Exit	(Orange)	- The exit button contacts are closed
Contact	(Orange)	- The door contacts are closed
Tamper	(Orange)	- The tamper contacts are closed
PSU	(Orange)	- The PSU contacts are closed
Net2Air	(Blue)	- Net2Air interface Tx/Rx activity
OK	(Green flash)	- The internal software is running

Net2Air wireless communication

Net2Air wireless control units are fully compatible with the hard wired Net2 range but there are several important differences that need to be understood before installing wireless equipment. The most important of these is the location of the control units and their bridge components.

These principles are therefore explained first before we move on to the control unit itself.

Lock output - This is a transistor 'open drain' output, (not a voltage free contact) that has been designed to simplify the wiring of the lock. It can be configured to operate in Fail lock, Fail unlock or toggle modes and removes the need for additional links or diodes normally required when using a relay for output switching.

Relay output - This provides a set of volt free contacts to switch external devices.

Alarm output - This is a transistor driven output that switches to 0V when activated.

Radio frequency

This product should not be installed within 3 metres of other wireless equipment operating on a 2.4Ghz frequency. To ensure optimum performance other wireless networks should avoid WiFi channels 11, 12 and 13 to reduce the possibility of interference.

A Net2 nano ACU or a Hands free interface cannot be installed in a Metal cabinet as this would block the RF signal used for the Net2Air wireless technology.

Net2 nano / server operation

Data transfer with wireless technology requires far more control and error checking than with a hard wired data line connection. Net2 classic runs with a server that originates and controls all the communications on the data line. This would not be efficient in a wireless environment.

We therefore give the Nano controller the active role. Each Nano is always active and transmits data bursts (including a regular Heartbeat) every few seconds. The Net2 server then acts upon these requests for service.

The PC requires at least one Net2Air bridge to communicate with a Nano. This can be a local Net2Air USB bridge (only one per system) and/or multiple Net2Air Ethernet bridge units connected to the PC via a TCP/IP connection.

There is NO Net2 nano detection function. It is recognised that there could be security issues if the wireless units were detectable from outside the site. During installation, a Nano unit binds to a Net2Air bridge which will then only talk to registered units. The Server Configuration Utility also has an ' Enable commissioning' mode which can be turned off to inhibit Nano units being added.

An entry is then made on the Doors screen and a special icon is used to denote the wireless connection. 

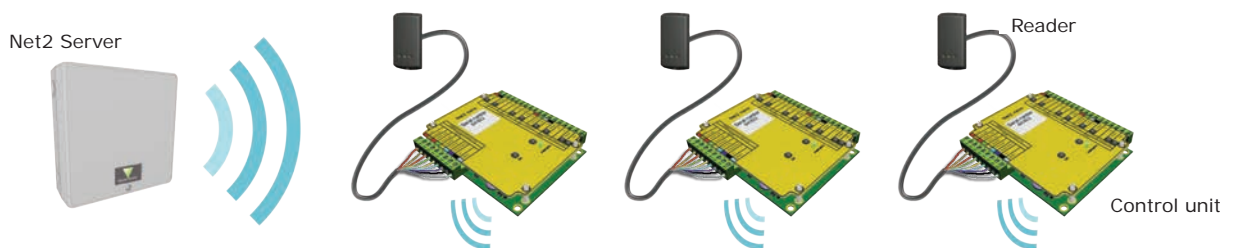

The reader's default indication has all the LED's on. Access granted is denoted with a single flashing Green LED. Access Denied is a single flashing Red LED.

Control unit installation

Wire the components to the Access Control Unit (ACU) as shown on the first page. This will include:

- Reader/Keypad
- Electric Lock
- Power supply
- Any other optional components

Press the exit button or in the absence of an exit button, short the 0V and exit terminals together. The lock relay LED will come on and the lock should release.

Software installation

The Net2 software should be loaded on the controlling PC and at least one Net2Air bridge configured to communicate with the unit.

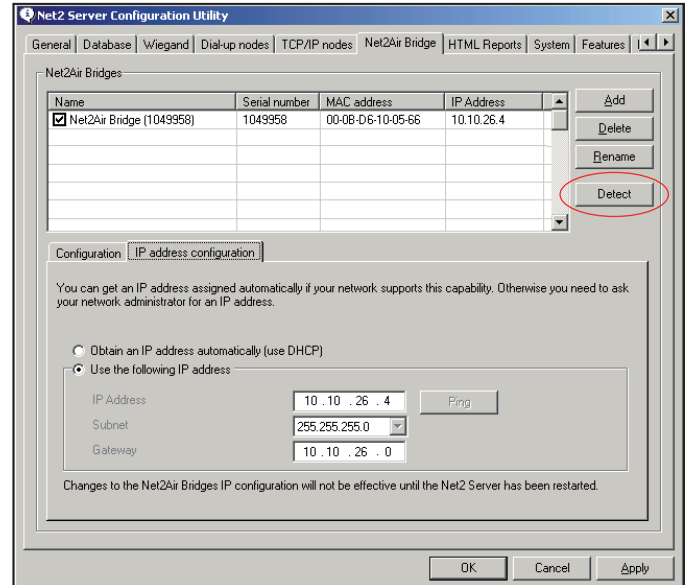
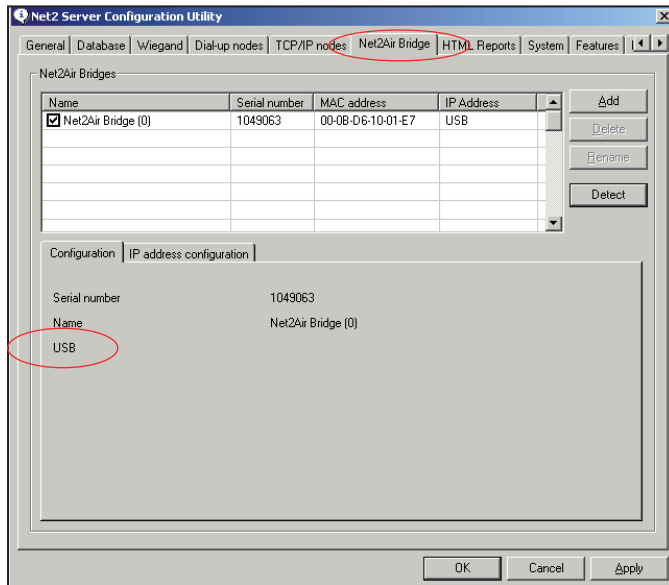

Only ONE Net2Air USB bridge may be used per system. Multiple Net2Air Ethernet bridges may also be configured. Full documentation is supplied with the Net2Air bridge unit and also on the website as follows:

- [AN1051 - Installing Net2 software < http://paxton.info/1520 >](http://paxton.info/1520)
- [Ins-30084 - Net2Air USB bridge < http://paxton.info/926 >](http://paxton.info/926)
- [Ins-30085 - Net2Air Ethernet bridge < http://paxton.info/920 >](http://paxton.info/920)

INPUT / OUTPUT WIRING

The Net2 nano has 3 outputs that can be configured in the Doors screen to perform different functions.

This flexibility means that a site that requires the Relay output (volt free contacts) for the door function can configure the Lock output to drive a door bell.

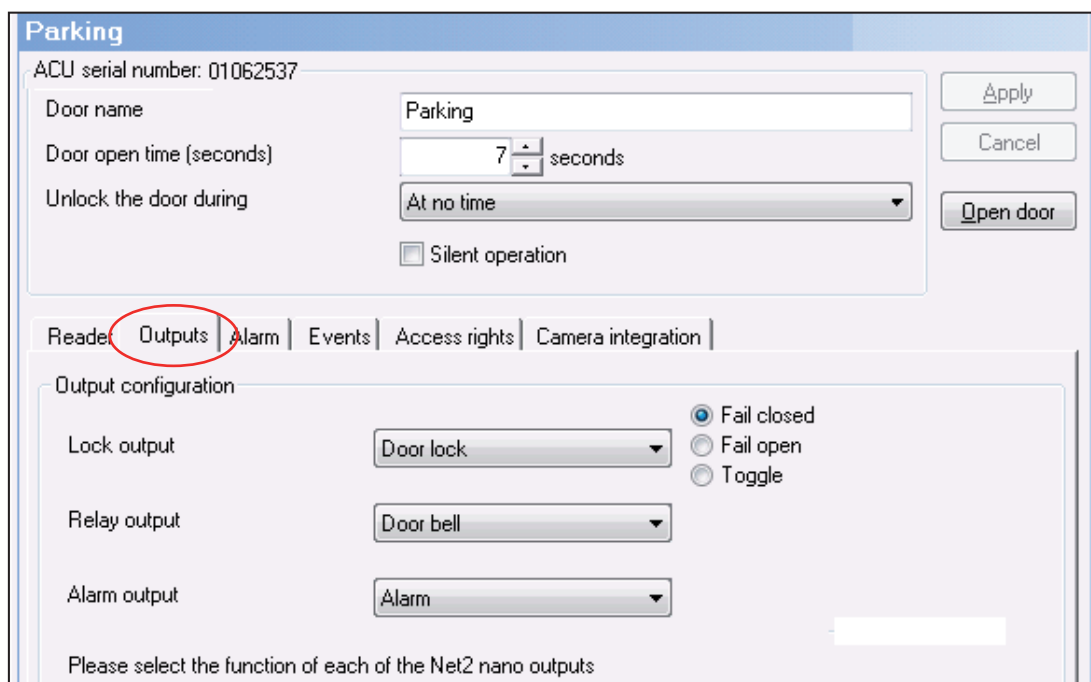

Lock output - This is a transistor 'open drain' output, (not a voltage free contact) that has been designed to simplify the wiring of the lock. It can be configured to operate in Fail lock, Fail unlock or toggle modes and removes the need for additional links or diodes normally required when using a relay for output switching.

Relay output - This provides a set of volt free contacts to switch external devices.

Alarm output - This is a transistor driven output that switches to 0V when activated.

Enrolling a Net2 nano

A Nano must bind to a Net2Air bridge before it will enrol itself onto the Net2 system. The term 'bind' is used to denote the fixed relationship between a Nano and its bridge.

Create a user record in the database and assign a Net2 token to the user. If you are not using PROXIMITY tokens you should still create the user record and assign a token number (Not a PIN) of your choice. These records can be deleted after the installation is complete.

Connect a PROXIMITY reader to the Nano and then present the same user token previously assigned. (If you are enrolling a Keypad only unit, enter the token number on the keypad followed by *) The Nano will then transmit the token number and wait for a response from a bridge.

If more than one bridge replies, the Nano checks the signal strength and selects the strongest bridge to communicate with. The Net2 software confirms that the token number is in the database and if so registers this Net2 nano/bridge binding.

Net2 nano reset

The Nano controller holds the address information for the bridge that it is bound with. This will cause problems if the unit is to be used on another system.

To clear this address information, you need to perform a hardware reset. Link Orange/Mauve on the reader port and then power cycle the unit.

Make sure that the power is not removed again until after the green OK LED is flashing again. Later versions of software also flash the reader LED's until the reset process has finished. Remove the Orange/Mauve link.

PC Installation

The current door specification for compatible PC hardware, network and operating systems is available on our website at the following link: <http://paxton.info/720>

Software Configuration

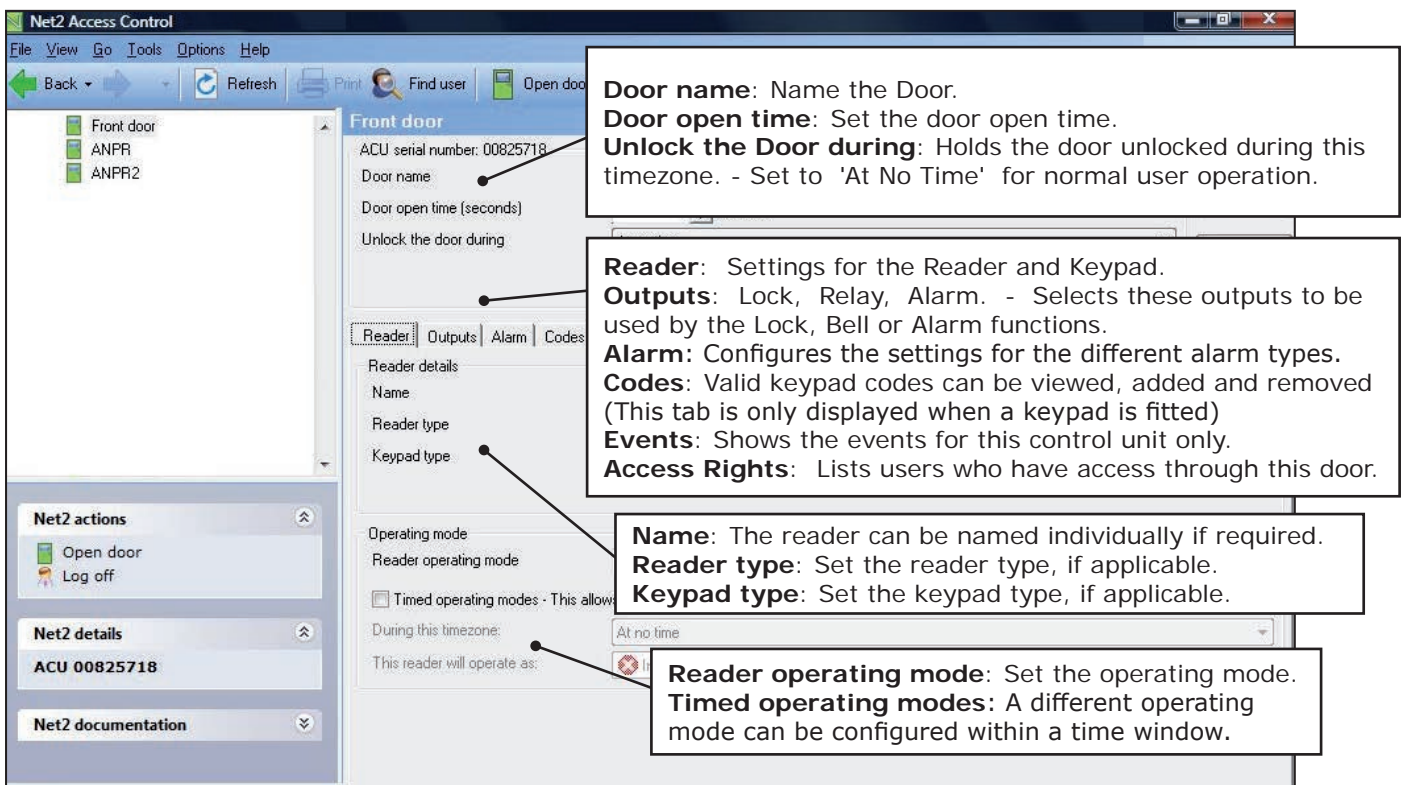

The screenshot shows the Net2 Access Control software interface. The main window displays configuration settings for a door named 'Front door'. The interface includes a menu bar (File, View, Go, Tools, Options, Help), a toolbar (Back, Refresh, Print, Find user, Open door), and a sidebar with 'Net2 actions' (Open door, Log off), 'Net2 details' (ACU 00825718), and 'Net2 documentation'. The main area shows 'Front door' settings: ACU serial number: 00825718, Door name, Door open time (seconds), and Unlock the door during. Below this are tabs for Reader, Outputs, Alarm, and Codes. The Reader tab is active, showing 'Reader details' (Name, Reader type, Keypad type), 'Operating mode' (Reader operating mode, Timed operating modes - This allows), and 'During this timezone' (At no time). Callout boxes provide detailed explanations for these settings:

- Door name:** Name the Door.
- Door open time:** Set the door open time.
- Unlock the Door during:** Holds the door unlocked during this timezone. - Set to 'At No Time' for normal user operation.
- Reader:** Settings for the Reader and Keypad.
- Outputs:** Lock, Relay, Alarm. - Selects these outputs to be used by the Lock, Bell or Alarm functions.
- Alarm:** Configures the settings for the different alarm types.
- Codes:** Valid keypad codes can be viewed, added and removed (This tab is only displayed when a keypad is fitted)
- Events:** Shows the events for this control unit only.
- Access Rights:** Lists users who have access through this door.
- Name:** The reader can be named individually if required.
- Reader type:** Set the reader type, if applicable.
- Keypad type:** Set the keypad type, if applicable.
- Reader operating mode:** Set the operating mode.
- Timed operating modes:** A different operating mode can be configured within a time window.

This product is not suitable for retail sale. All warranties are invalid if this product is not installed by a competent person.

Here is the list of topics about this product that receive the most technical support enquiries. We list them here to help you speed up the installation and trouble shooting process.

1 - ACU fails to enrol onto the PC (WIRELESS PROBLEMS).

The Net2 nano must be in range of a Net2Air bridge. Detailed advice can be found on the website as follows: -

[AN1095 - Net2 wireless access control < http://paxton.info/974 >](http://paxton.info/974)

[AN1096 - How to plan a Net2 wireless installation < http://paxton.info/975 >](http://paxton.info/975)

2 - Readers/keypads not working.

- Software settings - Confirm that the settings of the reader or keypad are correct.
- Connections - Check the wiring and integrity of the connectors. If possible, test this reader on the other unit.
- Cable - Belden 9540 should be used to extend the reader cable (Max 100 m). Twisted pair alarm cable should not be used. To confirm that a cable extension is not at fault, wire the reader directly to the reader port.
- Supply voltage - Confirm that the voltage is within specification. (see table)
- User token - Confirm that the user token used for testing is OK by presenting it to a known working reader.
- Interference - Confirm whether the reader works when tested 'in hand' and not mounted on the wall. Ensure that readers are not mounted back to back or there is no interference from other local RF devices.

3 - Why are some of the Net2 features (e.g. Fire alarm integration) not available on Net2 nano?

Wireless communication is not suitable for safety critical applications.

4 - Net2Air - What does this mean?

This is a term to describe the wireless communication protocol used by Paxton products in much the same way as Bluetooth, but the Net2Air protocol is not open. Only Paxton products can use this technology.

The Net2Air protocol is based on the standard known as IEEE 802.15.4. It operates at 2.4 GHz and can co-exist with wireless LAN networks and other devices using this frequency such as DECT phones. All Paxton products employ AES128 encryption technology to ensure that all communication remains secure.

Specifications			
Features	Min	Max	
Number of Cards		10,000	
Number of PIN's		10,000	
Access levels		250	
Time zones		64	
Maximum door open time	1 sec	99,999 sec	
Number of Codes		50	
Doors per ACU		1	
Reader ports per ACU		1	
Readers per port		2	
Keypads per port		2	
ACU's per Net2Air bridge - Recommended		10	
Net2Air bridge per system	1	100	
Net2Air wireless range		30 m	
Data retention after total power loss	60 days		
Events stored in ACU with no server connection		3,584	
Electrical	Min	Max	
Voltage	11V DC	14.5V DC	
PCB Current (depending on activity)		120 mA	
Relay switchable voltage		24V DC	
Relay switchable current		2 A	
Dedicated lock output current		1.1 A	
Alarm output current		1 A	
Reader port output current		500 mA	
Carrier frequency			2.405 GHz
Environment	Min	Max	
Operating temperature - Battery limits	0 °C	+ 55 °C	
Waterproof			No
Dimensions	Width	Height	Depth
Control Unit	105 mm	106 mm	23 mm
Plastic Housing	200 mm	200 mm	75 mm

CE0889

TPaxton Access Ltd hereby declares that this product is in conformity with all the essential requirements of the Directive 2014/53/EU. <http://paxton.info/3685>

The full declaration of conformity is available on request. Contact details are provided at: <http://paxton.info/596>